

Flex OPS™

The Ultimate Seat Back Organization & Storage Solution

Installation Instructions

Flex OPS™ (Outdoor Pocket System) is intended for installation only on seats with adjustable headrests.

Before installation, identify which Flex OPS™ unit is for the driver side, and which is for the passenger side. Near the top of the Flex OPS™, just above the logo tag, is a nylon strap with a side-release buckle. The Flex OPS™ should be installed so this buckle is on the inside edge of the seat.

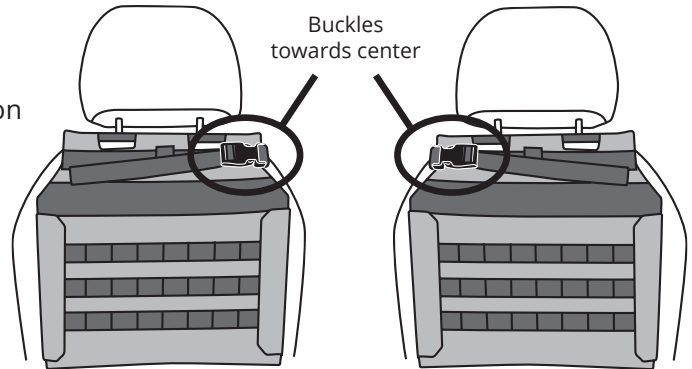

There are 2 methods for installing your Flex OPS™ on a vehicle seat:

Installation Method #1 For vehicles with fully removable headrests.

1. Pull up on your vehicle's headrest to remove it completely from the seat. Most seats have a small button on one of the post holes which must be pressed to allow for complete removal of the headrest.
2. Place the top side of the Flex OPS™ over the top of the seat and position the large slots to line up with the seat's headrest post holes. The plastic bar along the top edge of the Flex OPS™ should be on the forward side of the seat.

NOTE: There are additional straps attached to this top bar. These straps should be pulled back to hang behind the seat with the rest of the Flex OPS™.

3. Holding the Flex OPS™ in position, re-insert the headrest posts into the holes through the slots on the Flex OPS™. The plastic bar should rest against the forward side of both headrest posts. Adjust headrest to desired height.
4. Locate the long strap at the very bottom of the Flex OPS™. Run this strap around the base of the seat back and secure using the side-release buckle. If you have installed your Flex OPS™ on the correct side, this buckle should be positioned towards the outside edge of the vehicle, making it easier to access.
5. Tighten the strap as needed.

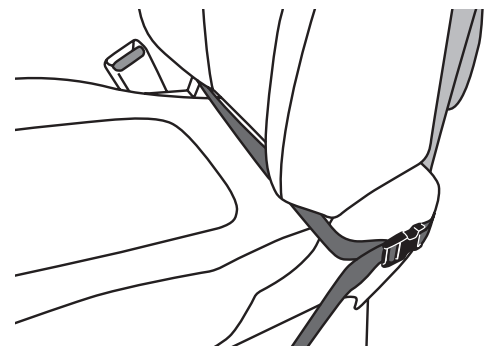
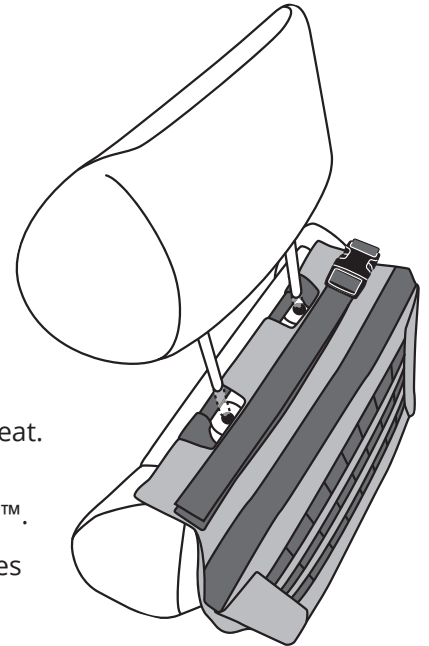

Installation Method #2

For vehicles with recessed headrests, non-removable headrests, or to allow the Flex OPS™ to hang lower on the seat back.

1. Pull up on your vehicle's headrest to expose the support posts.
2. Locate the two straps attached to the plastic bar along the top edge of the Flex OPS™. Run these straps underneath the headrest and around the outside of both posts.
3. Secure the side-release buckle and adjust the strap length as needed to raise or lower the Flex OPS™ to hang at the desired level. Adjust headrest to desired height.
4. Locate the long strap at the very bottom of the Flex OPS™. Run this strap around the base of the seat back and secure using the side-release buckle. If you have installed your Flex OPS™ on the correct side, this buckle should be positioned towards the outside edge of the vehicle, making it easier to access.
5. Tighten the strap as needed.

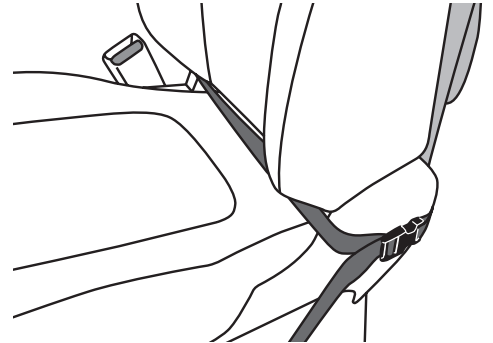
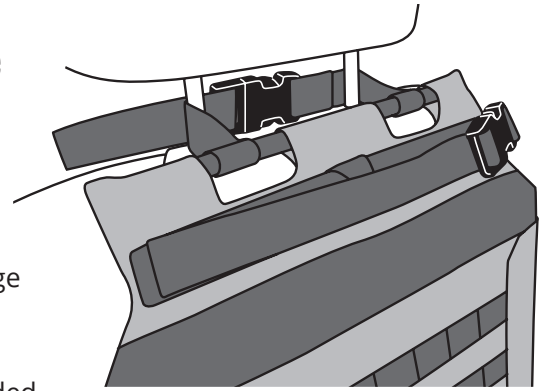

Compound Bow Instructions (Vertical Carry)

To carry most compound bows:

1. Locate the large open-top pocket on the bottom half of the Flex OPS™ unit (see illustration to right).
2. Place top limb and cam of the bow into the pocket, and secure the vertical strap across the center of the opening by attaching the hook & loop between the two front pockets (see illustration below left).
3. Bring the riser of the bow up against the top of the seat back. Secure in place using the top adjustable nylon strap with side-release buckle. To prevent rubbing, position the extra loop of strap material between the bow and the buckle (see illustration below right).

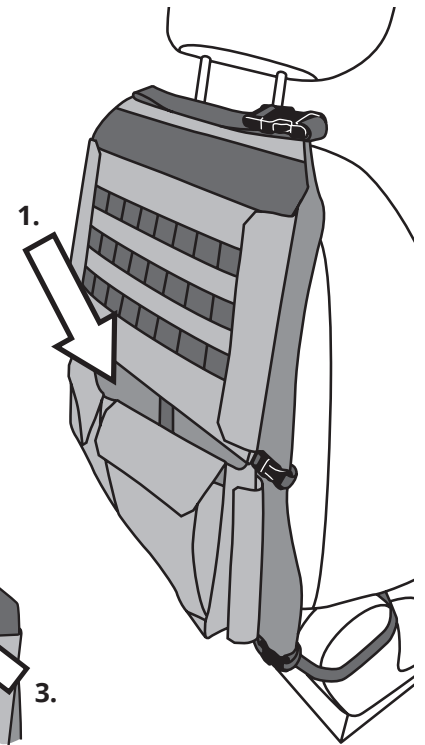
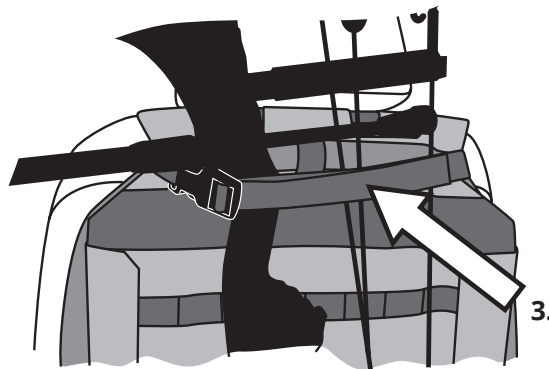
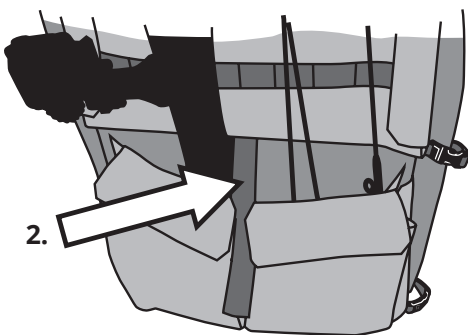

Tips for Use:

- Using Method #2 for attaching the Flex OPS™ to the seat may help adjust for different vehicles and different bow lengths. Tighten or lengthen the strap around the headrest to adjust the level at which the Flex OPS™ hangs.
- Reclining or raising the seat back will also affect the angle at which the bow is held.
- The bow may be easier to insert and remove from the large open-top pocket if the two front pockets are empty.

Rifle/Long Item Instructions (Horizontal Carry)

To carry longer items such as rifles, both Flex OPS™ units should be installed in the same seat row.

1. Locate the scabbard-style pockets, and open the vertical flaps on the inner edges (see illustration to right). The flaps can then be tucked inside the pocket and attached to the hook and loop strip on the inside, to keep them out of the way.
2. Slide one end of the rifle into the scabbard-style pocket on one side, pushing it in fully.
3. Move the opposite end of the rifle into position at the opening of the scabbard-style pocket on the other seat and slide the rifle partially into the pocket. The rifle should now have both ends in pockets, and should be suspended in the space between the Flex OPS™ units.

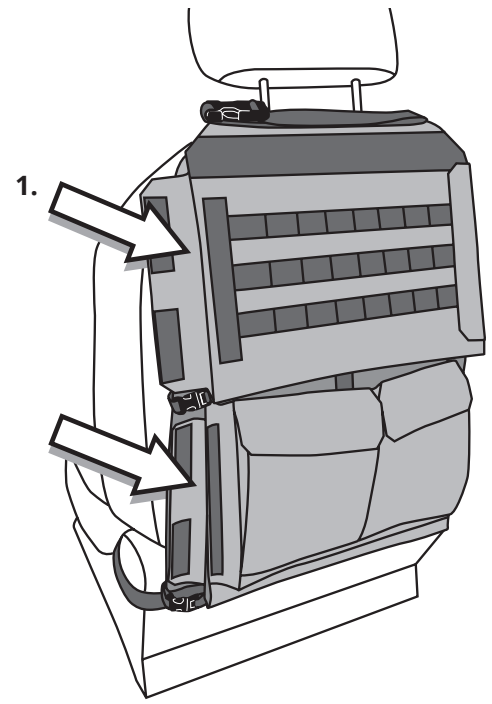
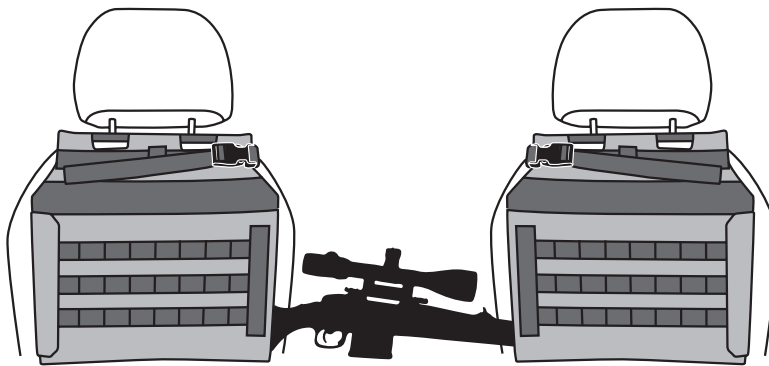

Note: There are two sets of these pockets, allowing storage of two rifles, one above the other.

Tips for Use:

- If your item is especially long, it may be necessary also to open the vertical flap on the outside edge of the pocket, to allow more room to maneuver the item into position.
- On some vehicles the center console may block the area between the two Flex OPS™ units. If this is the case, detaching the side-release buckles at the bottom corners of the scabbard-style pockets (see illustration to right) will allow the pocket to hang away from the seat back, and may create the clearance needed for the center console.
- If the Flex OPS™ is installed on adjustable seats, both seats should be adjusted to similar distances for the best possible positioning.
- ***Always obey local, state, and federal gun laws.***

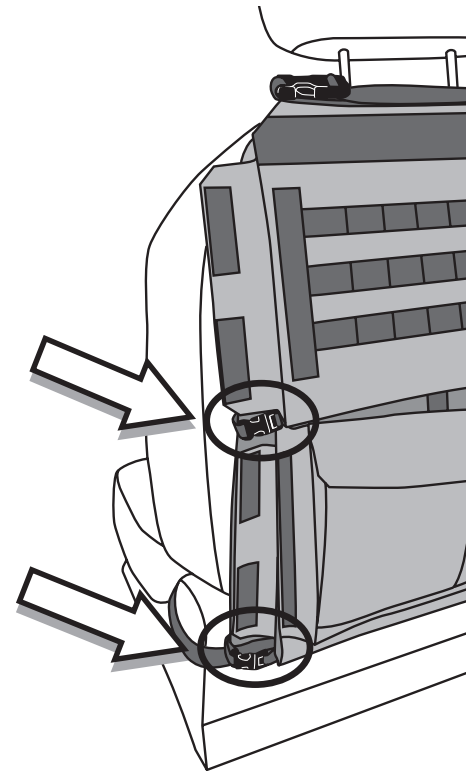

Crossbow Instructions (Vertical Carry)

To carry most crossbows:

1. Remove the side-release buckle from the adjustable nylon strap at the top of the Flex OPS™ unit. Run the strap through the loop in the center of the Flex OPS™ backing, then reattach the buckle to the strap (see both illustrations to right).
2. Locate the crossbow pouch, and unroll it from where it is stored behind the top pocket (see illustration below left).
3. Place the butt of the crossbow into the pouch.
4. Bring the top of the crossbow up against the top of the seat back, angling the crossbow towards the center of the vehicle to keep the limbs away from the vehicle door. Secure in place around the barrel using the top adjustable nylon strap with side-release buckle. To prevent rubbing, position the extra loop of strap material between the barrel and the buckle (see illustration below right).
5. When not in use, the crossbow pouch may be rolled up and re-secured behind the top pocket using the attached hook & loop strip.

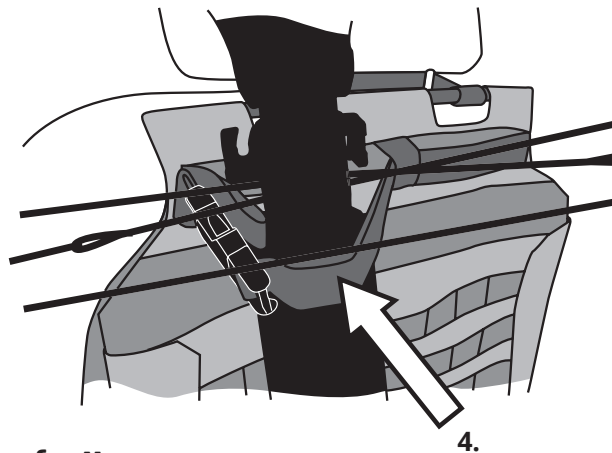
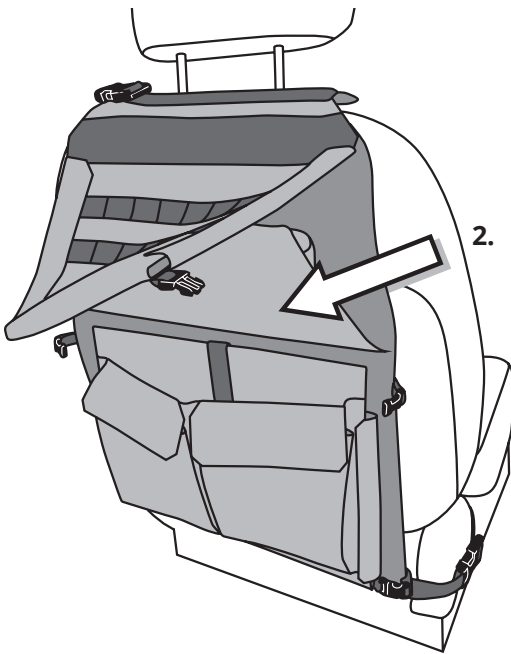
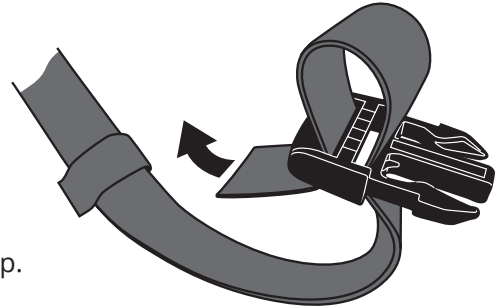
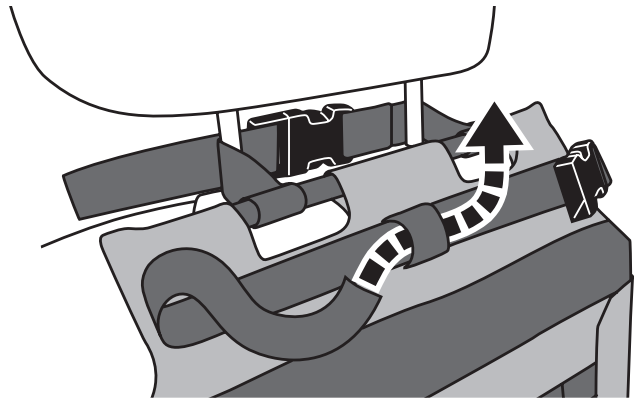

Tips for Use:

- Using Method #2 for attaching the Flex OPS™ to the seat may help adjust for different vehicles and different crossbow sizes. Tighten or lengthen the strap around the headrest to adjust the level at which the Flex OPS™ hangs.
- Reclining or raising the seat back will also affect the angle at which the crossbow is held.

US PATENT PENDING

Care Instructions

Clean your Flex OPS™ using a damp cloth or light brush, and allow to air dry thoroughly before using again. Do not use any alcohol-based cleaning agents.

